

ECOBULK

CHECK VALVE

Back-flow prevention for IBC outlet valves.



- Protects your filling good during discharge
- Minimising the risk of filling good contamination
- Ideal for pump discharging – ensures excellent draining capability
- Suitable for all non-sticky filling goods with low viscosity, such as foods, chemicals, pesticides, paints and varnishes

In case of technical concerns or questions: tcs@schuetz.net

SCHÜTZ
PACKAGING SYSTEMS

www.schuetz.net

Check valve

Integration in the discharge opening of the inner container

Feasible for all DN 50 types of SCHÜTZ outlet valves

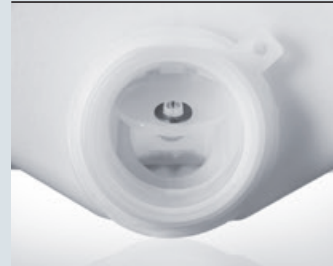

The check valve is open when the IBC is being emptied



The flap closes when the flow of the filling good stops

Pump discharging – excellent draining capability

Without a check valve: the pump draws in air and stops

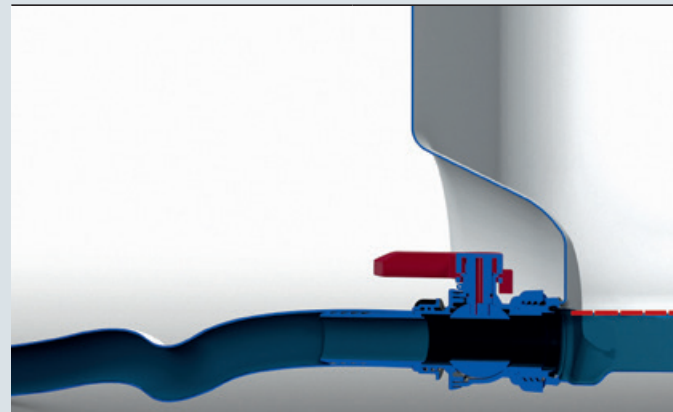

With a check valve: air draw occurs much later

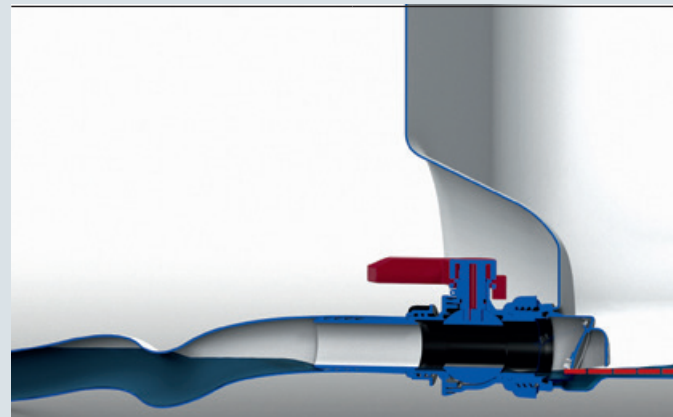

When emptied without a pump, an IBC with a check valve has the same excellent drainability as an IBC without check valve

Certifications

UN 31HA1/Y

U.S. EPA regulations on pesticide containers

Materials compliant with FDA (safe for food products)