



**ECOBULK HX**  
for high-viscosity filling products

Discover the new specialist for highly viscous filling products.

The **ECOBULK HX** dramatically reduces costs  
in your supply chain and provides maximum safety  
for the quality of your filling product.

**Paints & Coatings**

**Resins**

**Adhesives**

**Foods**

# Revolutionary design meets a comprehensive packaging concept.

**Our aim is to offer the ideal packaging solution for every filling product.  
The new ECOBULK HX was designed specially for use with viscous media.**

The ECOBULK HX, a 1,000-litre IBC, unites a compact size with outstanding technical characteristics for fast, simple filling and emptying. Whether performed gravimetrically or with the aid of a pump, residual emptying is practically 100%. The IBC is also designed to ensure optimum stirring processes, giving you perfect results, allowing even low filling levels to be completely stirred. Additionally, compared with steel multi-trip systems, the ECOBULK HX offers highly convincing cost and application benefits along the entire supply chain.

ECOBULK  
**HX**



- + OPTIMUM PROCESS SUPPORT
- + COMPREHENSIVE QUALITY PROTECTION
- + SUPREMELY COST-EFFECTIVE
- + COMPLETELY ADMINISTRATION FREE



The ECOBULK HX is integrated in **SCHÜTZ's comprehensive packaging concept**. It offers customers the assurance of knowing that their products are filled in packaging that complies with the highest cleanliness standards. And on top of that, **collection and reconditioning** of the containers protects natural resources and prevents CO<sub>2</sub> emissions.

# Perfectly configured for “optimum flow”.

Selecting the right packaging is not only a question of the properties of the filling product. As a rule, a packaged product will pass through many distinct process stages between filling and final use.

From automatic filling to high-rack storage transport in ISO containers, the use of agitators or discharge in ex-zones – the **ECOBULK HX** is designed to optimally comply with a wide range of different process requirements.

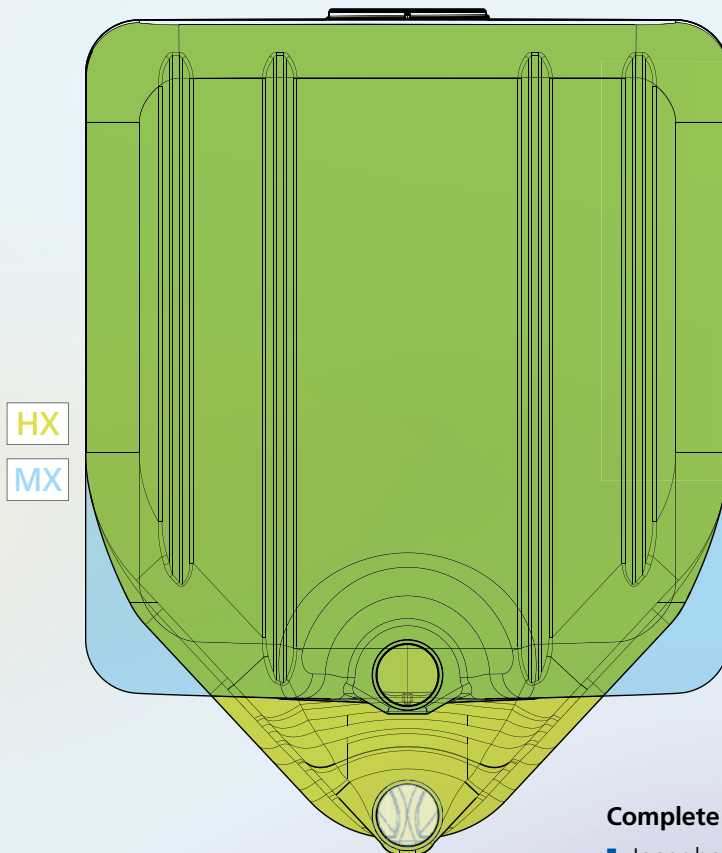

# ECOBULK HX

#### Complete residual emptying

- Inner bottle has a funnel-shaped bottom
- Low-lying discharge valve DN 80
- Residual emptying less than 0.3 litres, even for highly viscous products
- **When used with a pump:** the pump will stop due to air intake only when the container is completely empty



#### Filling opening

- Large DN 225 version
- Suitable for manual or automatic filling
- External stirrers can be easily inserted

#### Optional additional 556x4 filling opening

- Optimally designed for below surface filling
- Ideal in combination with the optional IMPELLER system
- The large screw cap can remain closed throughout the entire process

#### Optimised for use with agitators

- Excellent stirring results even with residual volumes as low as 50 litres
- **Tests prove:** faster and more efficient stirring processes thanks to the special geometry of the inner bottle

#### Approvals

- UN 1.9 hazardous goods approval for all standard liquids
- With an optional 3-layer inner bottle suitable for use in ex-zones 1+2

#### Stability

- Robust steel grid made of galvanised steel with 4-point welding of the vertical and horizontal tubes
- Closed, stable supporting cushion provides optimum support for the inner bottle

#### Product purity

- Plastic skid pallet also available for ex-zones
- Optional: FOODCERT Standard for the highest food safety
- Optional: CLEANCERT Standard for the highest technical cleanliness and safety
- Optional: supplied with the SCHÜTZ IMPELLER

Minimise the risk of your filling products becoming contaminated!

Our new packaging standards FOODCERT and CLEANCERT offer additional safety – starting from the production process.

Detailed HACCP risk analyses and preventive programmes in production based on these data guarantee the highest packaging cleanliness.



PACKAGING  
PRODUCTION



PACKAGING  
DELIVERY

# Comprehensive quality protection for your filling products.

Extend the protection of your filling goods right up to process level! Every time the packaging is opened, foreign substances and particles can get inside. This is a particular problem in mixing and stirring processes performed with multiple-use agitators. With the SCHÜTZ IMPELLER you can eliminate this risk while at the same time increasing process safety and user friendliness.



Discover the new full solution for more safety and efficiency in your supply chain:  
**ECOBULK with the SCHÜTZ IMPELLER!**

- The ECOBULK HX is supplied ex-works with a one-way stirrer.
- Depending on the process and container configuration the container can be filled without removing the IMPELLER.
- After filling the ECOBULK remains closed throughout the entire supply chain right until the filling product is discharged – including during stirring processes.
- There is no risk of contamination caused by product residues on multiple-use stirrers, hence eliminating the need for time-consuming cleaning and controls.
- Existing agitator drives can be easily and quickly attached to the **SCHÜTZ IMPELLER**



Eliminating contamination risks:



FILLING



TRANSPORT



STORAGE



MIXING &  
STIRRING  
PROCESSES



DISCHARGING  
FILLING  
PRODUCT

With the SCHÜTZ IMPELLER, ECOBULK containers can remain closed throughout the entire supply chain until the product is discharged!

# Achieve the highest economic efficiency in your supply chain!

With the **ECOBULK HX** you can save time and effort.

Compared with conventional steel multi-trip containers, our ECOBULK IBCs eliminate quality risks for your product and lower your quality costs.

The SCHÜTZ IMPELLER provides the highest degree of process safety, even during stirring and mixing processes.

## Collection and reconditioning

- Collection and environmentally friendly reconditioning, including 100 % material recycling of the HDPE in the SCHÜTZ ECOBULK including the IMPELLER
- No longer necessary to stock, clean or repair containers or agitators

## Emptying

- Faster emptying thanks to the geometry of the ECOBULK HX

## When using a pump:

- The pump will stop due to air intake only when the container is completely empty

## Stirring

- The geometry of the ECOBULK HX provides the ideal environment for stirring processes – requiring up to 75 % less time, depending on the filling product

## With the SCHÜTZ IMPELLER:

- Clean and efficient stirring processes without needing to open the container
- No danger of contamination due to product residue on multiple-use stirrers



### Procurement Containers & Stirrers

- Much lower acquisition and capital commitment costs

### Administration

- No tracking or management required for the container pool

### Delivery of empty packaging

- More efficient transport thanks to low tare weight and less space requirement

### Filling

- ECOBULK HX are always "ready to fill" with a new inner bottle fresh from the factory
- Compared with washed containers there is no risk of contamination caused by product remains or poorly cleaned packaging
- Suitable for fully automatic or manual filling

### With the SCHÜTZ IMPELLER:

- Filling through the optional S56x4 filling opening

### Transport and storage

- Excellent characteristics for handling, stackability and efficient use of space (e.g., a stack of three is only 4.05 m high)

### Preparing the agitator

#### With the SCHÜTZ IMPELLER:

- No need for labour-intensive, time-consuming cleaning and inspection of external steel agitators
- Simple adaption of existing agitator drives



# Maximum flexibility thanks to complete freedom from administration.

One key for the **global success of our IBC system** is its international compatibility and global exchangeability. Our customers benefit from the greatest degree of flexibility in their distribution and logistics processes.

As a cost-effective and completely administration-free packaging, the ECOBULK HX is ideal for **international exports**. Once the IBC has been emptied by the customer at the destination it can be returned for reconditioning, At the same time, the ECOBULK HX is the ideal packaging for establishing fixed **multiple-use recycling systems** without having to handle tracking, collection and reconditioning. This enhances the economic and ecological advantages of the system even more.





# SCHÜTZ TICKET SERVICE

**The SCHÜTZ TICKET SERVICE handles the fast collection and environmentally friendly reconditioning of the empty containers.**

After registering for free and without obligation all the customer needs to do is order the collection online, through the app, by e-mail or phone.

Collected containers are reconditioned using a globally standardised process. The steel cage and pallet are cleaned and reused. The inner bottle is removed and replaced with a brand new original inner bottle including a new screw cap and outlet valve. The components that are removed are recycled for materials, 100 % of which are used to make new IBC components.



Do you have further questions about the SCHÜTZ ECOBULK HX?

**We will be happy to help: +49 2626 77 0**

SCHÜTZ GmbH & Co. KGaA · Schützstraße 12 · D-56242 Selters  
Phone +49 2626 77 0 · Fax +49 2626 77 365  
info1@schuetz.net · www.schuetz.net

